



EDGE 40 Oven Cutsheet

General Information:

EDGE40 Conveyor ovens are designed to be stacked three high. Each oven has a 32" wide conveyor belt and a 40" long baking chamber. A triple stack of EDGE40 ovens can produce large volumes in a fairly small footprint.

Customer _____

Job Number _____

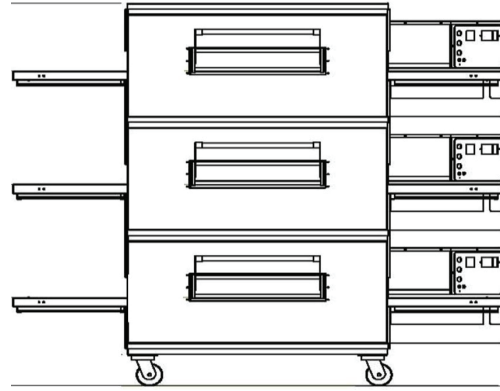

E40MNG-1 E40MLP-1
E40MNG-2 E40MLP-2
E40MNG-3 E40MLP-3

Standard Features:

- **AFFORDABLE:** EDGE40 ovens are affordably priced with an initial acquisition cost not much higher than a good quality reconditioned oven.
- **ENERGY EFFICIENT:** EDGE40 ovens use a modulating burner that modulates both gas and combustion air. This system allows for the lowest overall operating costs of any conveyor oven in its class.
- **LOW OPERATING COSTS:** Overall operating costs of the EDGE40 oven is about 74 cents per hour based on an oven temperature of 475 deg F, electricity costs at 10 cents per kwh, and natural gas costs at \$1.30 per Ccf.
- **MODULAR DESIGN (OPTIONAL):** EDGE40 ovens use a patented modular design that enables the oven to be bolted together instead of riveting and welding. This design allows the ovens to be installed in pieces without the use of any special lifting or rigging equipment.
- **REMOVABLE CONTROL CABINET:** EDGE40 control cabinet houses all the electrical and gas components except for the main motor. The control cabinet can be unbolted and returned to the factory for service or upgrades. An additional control can may be used as a spare to eliminate any costly down time.
- **CONSTRUCTION:** EDGE40 ovens are manufactured to exacting tolerances and use stainless steel inside and out.
- **WARRANTY:** EDGE40 ovens come with a detailed FIVE Year Parts and Labor Warranty.
- **VENTALATION:** EDGE40 ovens must be used under a ventilation hood only. Hood system must conform to all local and applicable codes.
- **BRUSHLESS:** EDGE40 ovens use a brushless drive conveyor system eliminating the need to replace brushes in the conveyor motors.



MF&B Restaurant Systems, Inc.
133 ICMI Road • Dunbar, PA 15431
1.888.480.EDGE • www.edgeovens.com

EDGE

O V E N S

Customer _____

Job Number _____



E40MNG-1 E40MLP-1
E40MNG-2 E40MLP-2
E40MNG-3 E40MLP-3

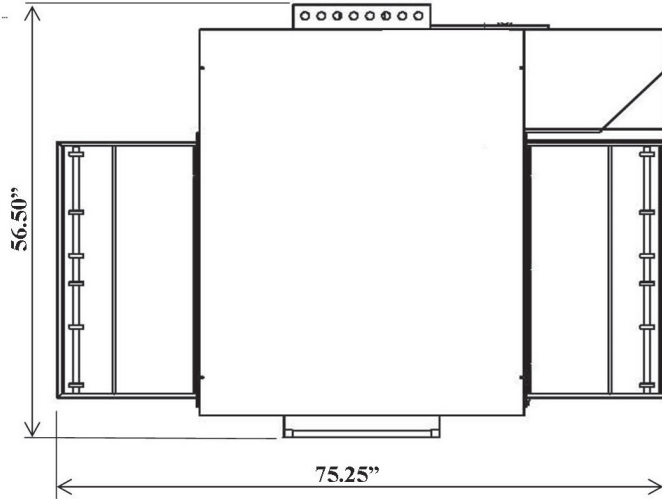

EDGE40 TOP VIEW

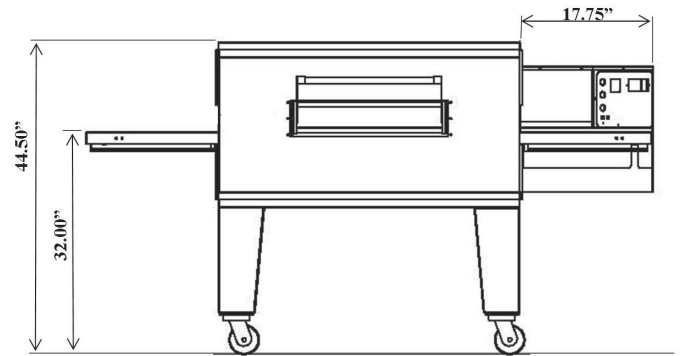

EDGE40 SINGLE

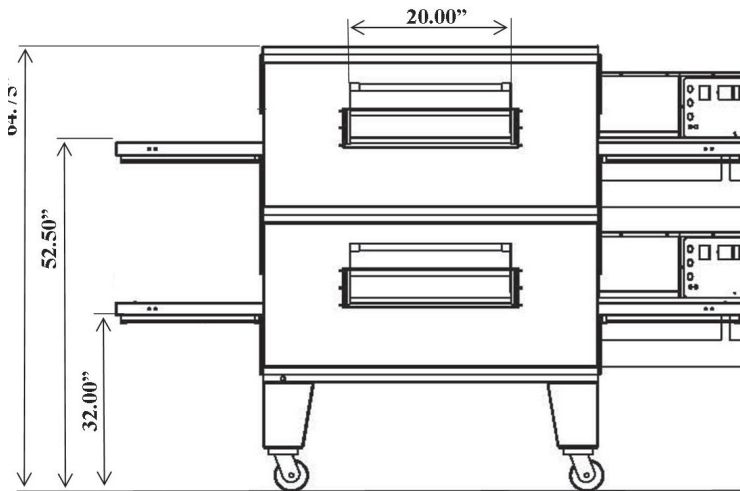

EDGE40 DOUBLE

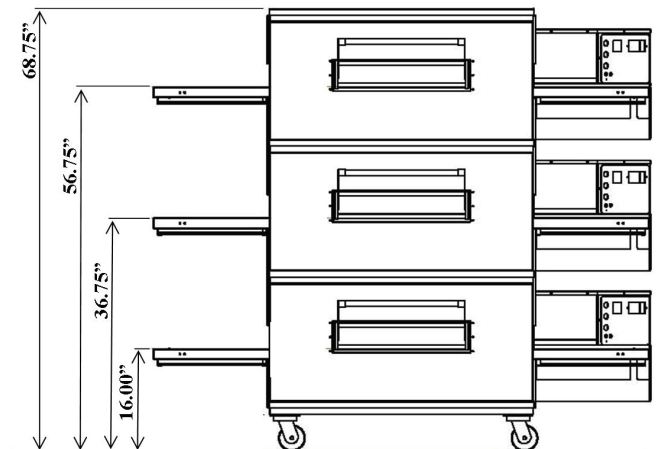

EDGE40 TRIPLE

GAS TYPE	VOLTS	FREQUENCY	AMPS	SUPPLY PRESSURE	BTU RATING	MANIFOLD PRESSURE
NATURAL	120	60 Hz	5.5	4.5" - 8" WC	120,000	4.5" WC
PROPANE	120	60 Hz	5.5	10" - 13" WC	120,000	10" WC

MF&B Restaurant Systems, Inc. • 133 ICMI Road • Dunbar, PA 15431
1.888.480.EDGE • www.edgeovens.com